

Spare parts list

Pusher legs

(ES) Lista de piezas de repuesto
Empujadores

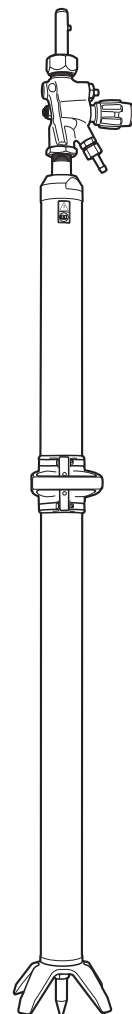

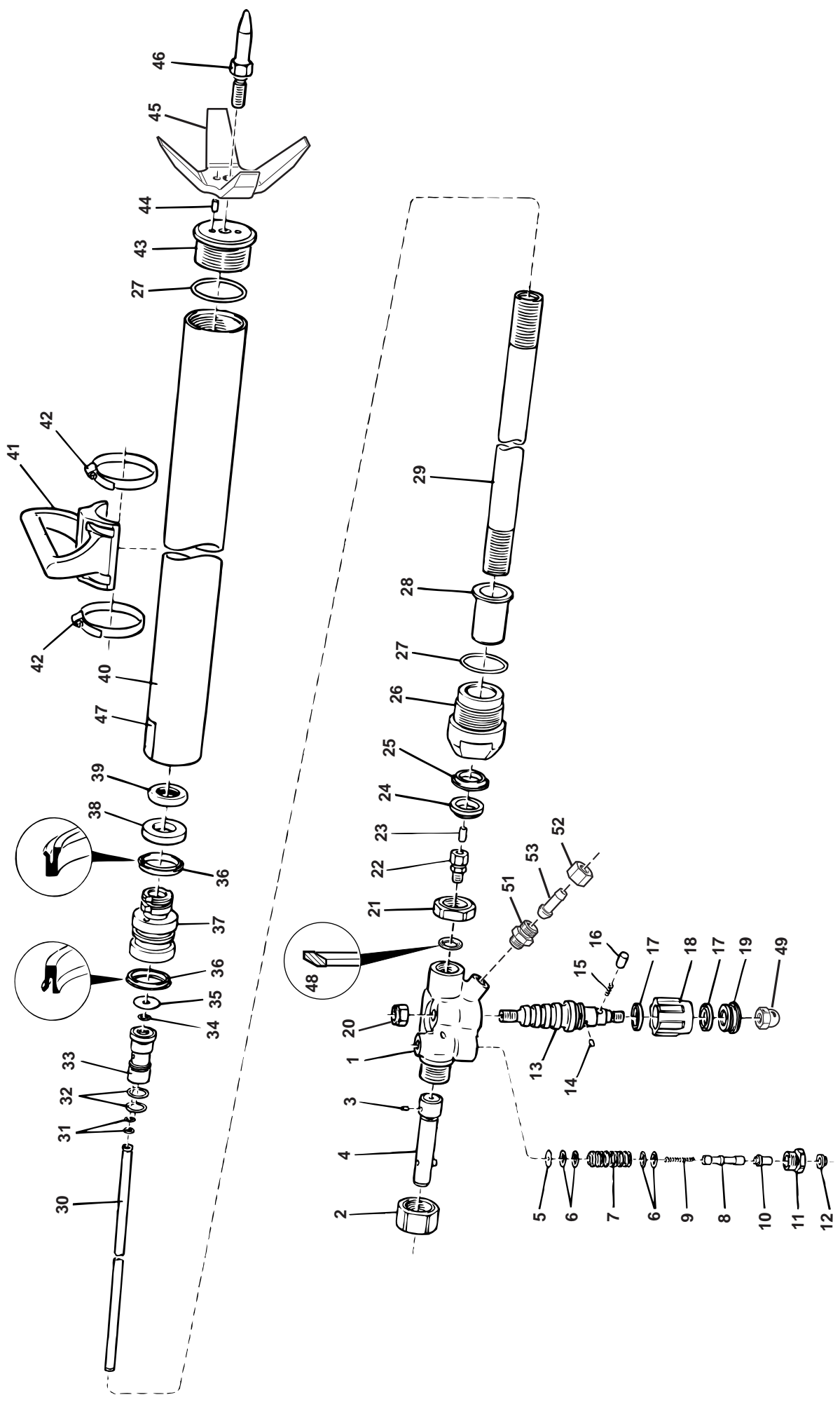

**Pusher leg
Empujador**

**ALF 72D (8321 0201 80)
ALF 72D-1 (8321 0201 81)**

Ref. No.	Part number Núm. de pieza	Qty. Cant.	Description	Designación	Remarks Observaciones
1	3115 3001 00	1	Valve housing	Caja de válvulas	
2	3115 2193 00	1	Cap nut	Tuerca de unión	
3	0101 2311 00	1	Cylindrical pin	Pasador cilíndrico	CP 6x10
4	3115 2999 00	1	Piston rod end	Extremo de vástago de pistón	
5	3121 0724 00	1	Washer	Arandela	
	3121 0726 80	1	Valve compl.	Válvula compl.	
6	0663 2124 00	4	- O-ring	- Junta tórica	17,3x2,4
7	— *)	1	- Valve liner	- Camisa de válvula	
8	— *)	1	- Valve	- Válvula	
9	3121 0725 00	1	Spring	Muelle	
10	3122 0382 00	1	Valve pin	Pasador de válvula	
	3122 0383 80	1	Adapter compl.	Adaptador compl.	
11	— *)	1	- Adapter	- Adaptador	
12	0665 9110 01	1	- Wiper	- Rascador	
13	3115 2998 00	1	Hand wheel bracket	Ambrazadera de volante de maniobra	
14	3115 0506 00	1	Pin	Pasador	
15	3000 9140 04	1	Pressure spring	Muelle tensor	
16	3121 0799 00	1	Detent pin	Pasador de inmovilización	
17	3115 0504 00	2	Seal kit	Juego de sellos	
18	3115 0505 00	1	Control knob	Mando de control	
19	3115 2195 00	1	Washer	Arandela	
20	0291 1128 25	1	Lock nut	Tuerca de apriete	M16-8 fzb
21	3115 2194 00	1	Nut	Tuerca	
22	0580 0013 14	1	Pipe coupling	Acoplamiento para tubo	GA 12-L/R1/4"
23	0581 2025 13	1	Insert sleeve	Casquillo de suplemento	8/10 MS
24	0665 9166 00	1	Wiper	Rascador	
25	3122 0176 00	1	Seal	Sello	
26	3115 2567 00	1	Guide socket	Manguito guía	
27	0663 6137 00	2	O-ring	Junta tórica	64,5x3
28	3122 0178 00	1	Bushing	Casquillo	
29	3115 2181 03	1	Piston rod (ALF 72D)	Vástago de pistón (ALF 72D)	
29	3115 2181 05	1	Piston rod (ALF 72D-1)	Vástago de pistón (ALF 72D-1)	
30	3115 3000 01	1	Centre pipe (ALF 72D)	Tubo central (ALF 72D)	
30	3115 3000 02	1	Centre pipe (ALF 72D-1)	Tubo central (ALF 72D-1)	
31	0663 2118 00	2	O-ring	Junta tórica	11,3x2,4
32	0663 2128 00	2	O-ring	Junta tórica	26,2x3
33	3115 2292 00	1	Insert	Suplemento	
34	0663 2120 00	1	O-ring	Junta tórica	13,3x2,4
35	3115 2569 00	1	Washer	Arandela	
36	3115 2105 00	2	Seal	Cierre	
37	3115 2336 00	1	Piston	Pistón	
38	3115 2310 00	1	Damper	Amortiguador	
39	3115 2311 00	1	Brake ring	Anillo de freno	
40	3115 2566 01	1	Cyl. barrel (ALF 72D)	Cuerpo del cilindro (ALF 72D)	
40	3115 2566 02	1	Cyl. barrel (ALF 72D-1)	Cuerpo del cilindro (ALF 72D-1)	
41	3115 2198 00	1	Handle	Empuñadura	
42	0347 6116 00	2	Hose clip	Sujetador de manguera	77-89 fzb
43	3115 2568 00	1	End piece	Pieza terminal	
44	0101 2357 00	2	Cylindrical pin	Pasador cilíndrico	CP 8x16
45	3115 2954 00	1	Support	Apoyo	
46	3115 2178 00	1	Spike	Punta	
47	3115 2629 00	1	Safety label (see instruction book)	Etiqueta de seguridad (ver libro de instrucciones)	
48	3177 0072 00	1	Lock washer	Arandela de retención	
49	3115 2996 00	1	Cap nut	Tuerca de unión	
51	9000 0341 00	1	Hexagon nipple	Boquilla hexagonal	
52	9000 0331 00	1	Cap nut	Tuerca de unión	
53	9000 0322 00	1	Hose nipple	Boquilla para manguera	1/2"

Optional equipment / Equipos optativos

3115 2094 00	1	Mandrel for fitting of part (36)	Botador para montaje de la pieza (36)
0462 1201 28	1	Socket wrench for removing and fitting of part (22)	Llave para desmontaje y montaje de la pieza (22)

*) not delivered separately / no se suministra aparte



Any unauthorized use or copying of the contents or any part thereof is prohibited.
This applies in particular to trademarks, model denominations, part numbers and drawings.

© 2006 Atlas Copco Construction Tools AB, Stockholm, Sweden | No. 9800 0723 23 | 2006-11-20